

■ EPQ315 General Parameter / Outline Drawing

General Parameter	Model	EPQ315			
	0~90° Travel Time	≤5S			
	Max Torque	50N·m			
	Motor power	30W			
	Voltage	AC24V	DC24V	AC110V	AC220V
	Rated Current(A)	5	4	1.7	0.75
	Locked-rotor current(A)	6.9	6.3	2	1.3
	Control Mode	E-Electronic on-off		S-Smart on-off	
	Rotation Angle	0~90°		0~90~180°/0~270°	
	Duty Cycle	25%			
	Environment Temp.	-13~158°F		-25~65°C	
	Weight	2.6kgs			
	Field Operation Modular	N		Y	
	Manual Operation Type	Wrench			
	Protection Grade	IP67/NEMA 4/NEMA4X/NEMA6/NEMA6P			
	Electric Connection	2*1/2NPT cable gland with 1m wire			
	Motor	Brushless DC motor			
	Multi-level protection	Double-level over heat protection(motor/interior actuator)&Over current protection			
	Indicator	360° Visible indicator / 360° Visible LED indicator			
	Heater	15W,The heater works when the ambient temperature is lower than 15°C			
Corrosion Protection	Aluminium alloy enclosure with ISO 12944 C03-02 standard powder painting				
Feedback Signal	Open/Close/Error		3 programmable relays output feedback signals		
Bus Type	Modbus				
Optional Function	Bluetooth/IP68/25°C heater/C05 corrosion protection				

EPQ315

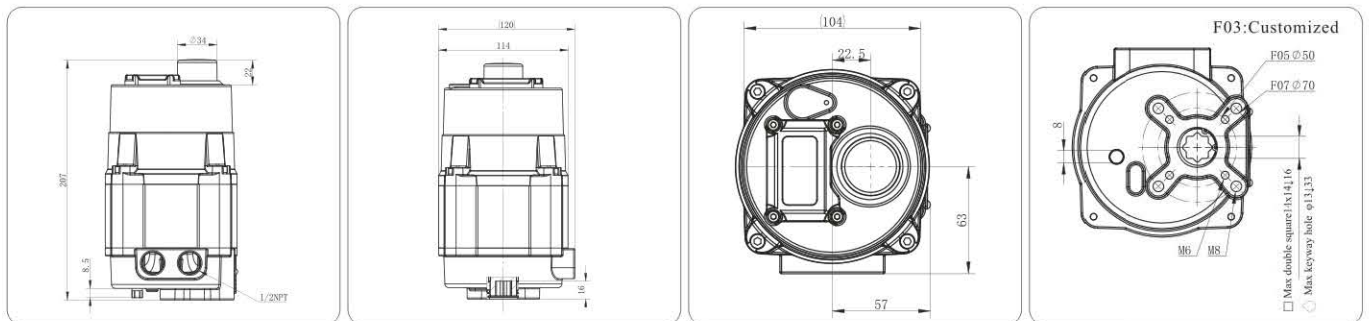

■ EPQ 0~90° ≤5 Sec Quick Open Series General Parameter

Series	Model	0~90°Travel time(S)		Max Torque(N·m)		Max Torque(in-lb)	
		AC/DC24V	AC110V AC220V	AC/DC24V	AC110V AC220V	AC/DC24V	AC110V AC220V
EPQ	EPQ115	≤5	≤5	8	8	71	71
	EPQ215	≤5	≤5	23	23	204	204
	EPQ315	≤5	≤5	50	50	443	443
	EPQ415	≤5	≤5	80	80	708	708
	EPQ425	≤5	≤5	120	150	1062	1328
	EPQ515	/	≤5	/	300	/	2655
	EPQ525	/	≤5	/	400	/	3540
	EPQ535	/	≤5	/	500	/	4425
	EPQ545	/	≤5	/	650	/	5753

